

ECMC

BRAND GUIDE

VERSION 1.0
SEP 2013

1. CIRCLE

- A. It should convey the male symbol, only slightly modified in proportions.
- B. All items are relative to the diameter of the inner circle, demarcated by the size X.
- C. The outer circle is sized at 1.5 times the diameter.
- D. Width of logo is 2.25X

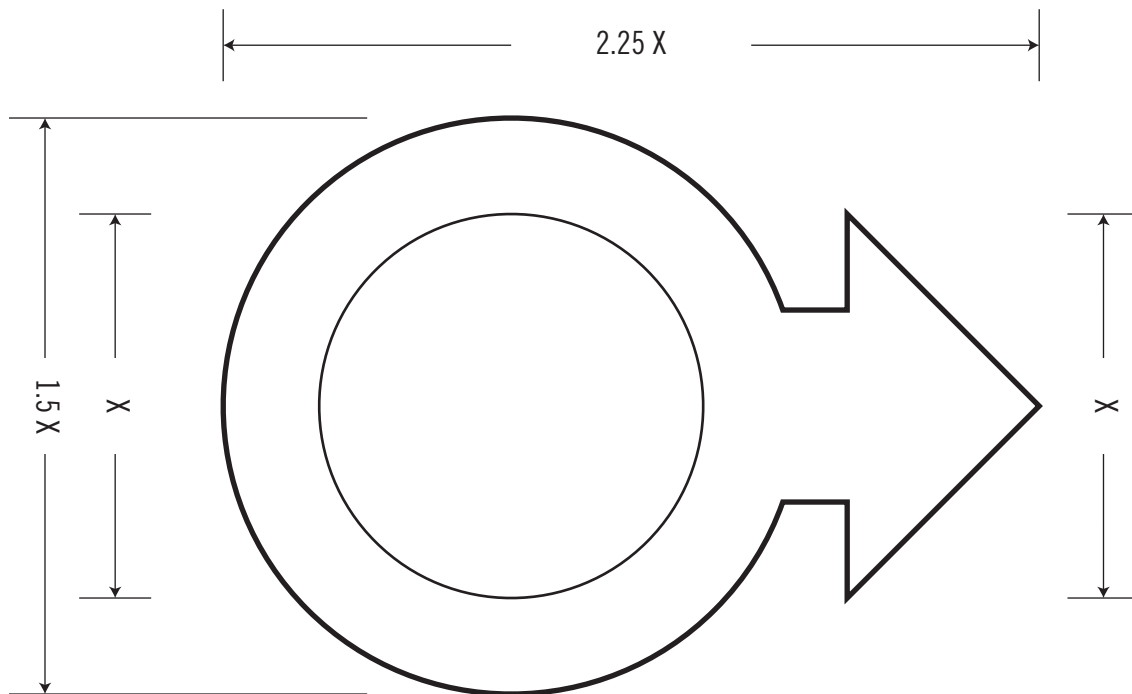

2. ARROW

- A. The width of the arrow flare is the same size as the width of the inner circle, X .
- B. Arrow's edges must be perfectly vertical or horizontal.
- C. Arrow is a cross section of a perfect square, cut on the diagonal.

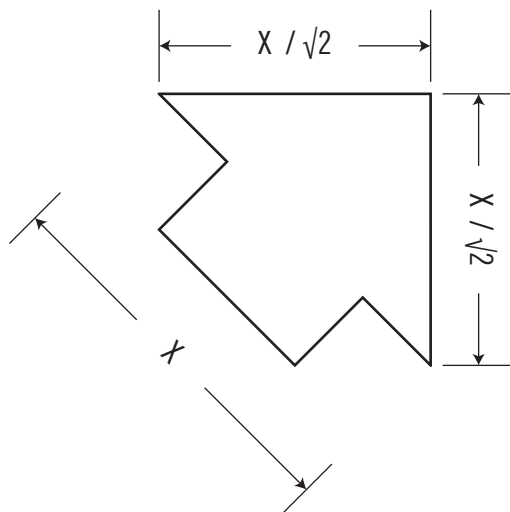

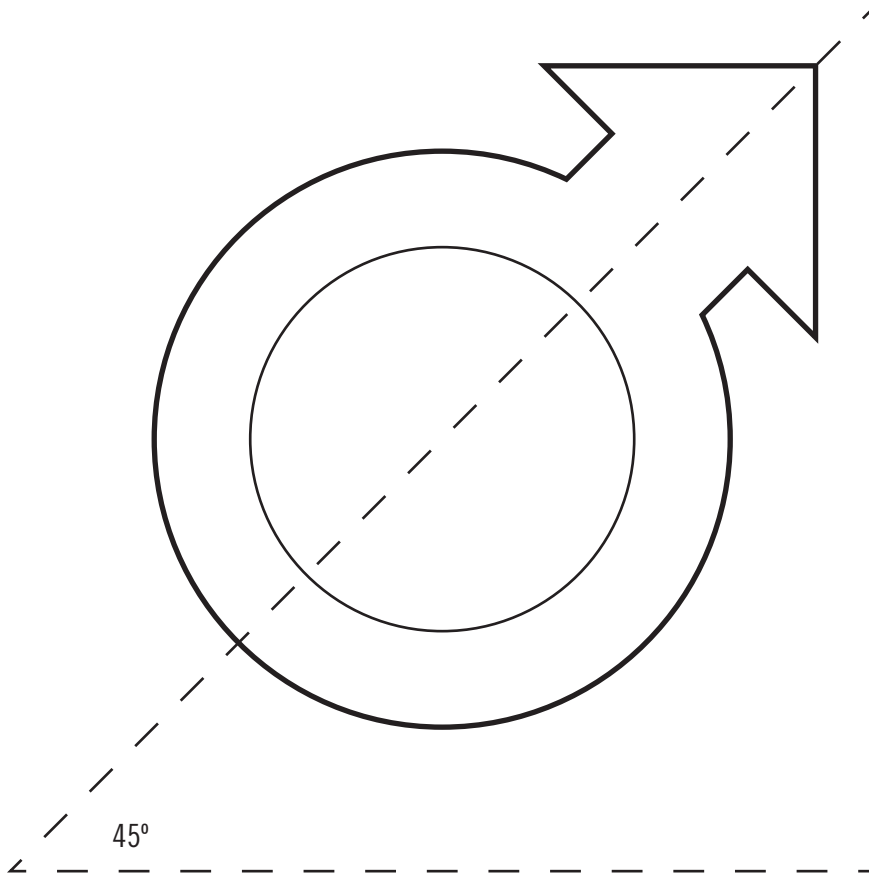

3. CIRCLE AND ARROW ANGLE RELATIONSHIPS

- A. Diagonal lines convey dynamic movement.
- B. The composite image is rotated at 45°.
- C. The image is balanced on both sides of the diagonal axis..



4. COLOR SWATCHES

- A. Printed materials. Use pre-defined color breaks as specified by Pantone Matching System. Where available, PMS186 should be used as a spot color.
- B. Web colors. Closest match using RGB values.
- C. Fabric. Best visual match to a Pantone swatch chip. Fabric and threads should be washed at least once before any attempts of matching color. Of the 3 swatches, the red ink is the most difficult to match.

	Pantone Reflex Blue		Pantone Yellow 012		Pantone 186
	CMYK (100 / 93 / 0 / 2)		CMYK (2 / 13 / 100 / 0)		CMYK (0 / 100 / 100 / 10)
	RGB (23 / 23 / 150)		RGB (253 / 214 / 0)		RGB (230 / 0 / 0)

5. LOGO TYPE TREATMENT

- A. Spelling out the MC. It avoids confusion. For the general uneducated public, MC could mean several items: Mistress of Ceremonies, Master Control, Men's Club, Main Core, etc.
- B. Using proper symmetry to skew and rotate text. Broken titled baselines and improper bloating effects make letters harder to read and place emphasis on the wrong items.
- C. Two options to include text inside circle as well as placed adjacent to the logo.

6. TEXT TREATMENT

- A. Use ITC Machine as the typeface for headlines. It can be well stretched horizontally and vertically without losing too much legibility. This font family does not have a lower case set of characters. Do not use as body text. Minimum use is 18 points. In absence, use any generic Futura font.
- B. For body text, use Trade Gothic family of fonts. It has a complete family of multiple weights. The preferred weight is Condensed18. It conveys an authoritative message without shouting for attention. It brings neatness in chaotic layouts. In absence, use generic Helvetica for body text.

THE QUICK BROWN FOX JUMPS OVER THE LAZY DOG.

ITC Machine Medium

The quick brown fox jumps over the lazy dog.
Trade Gothic Condensed 18

The quick brown fox jumps over the lazy dog.
Trade Gothic Condensed 18 Oblique

The quick brown fox jumps over the lazy dog.
Trade Gothic Bold Condensed 20

The quick brown fox jumps over the lazy dog.
Trade Gothic Bold Condensed 20 Oblique

The quick brown fox jumps over the lazy dog.
Trade Gothic Light

The quick brown fox jumps over the lazy dog.
Trade Gothic Light Oblique

The quick brown fox jumps over the lazy dog.
Trade Gothic Regular

The quick brown fox jumps over the lazy dog.
Trade Gothic Oblique

The quick brown fox jumps over the lazy dog.
Trade Gothic Bold

The quick brown fox jumps over the lazy dog.
Trade Gothic Bold No.2

The quick brown fox jumps over the lazy dog.
Trade Gothic Bold No.2 Oblique

The quick brown fox jumps over the lazy dog.
Trade Gothic Bold Oblique

The quick brown fox jumps over the lazy dog.
Trade Gothic Extended

The quick brown fox jumps over the lazy dog.
Trade Gothic Bold Extended